

Model: F03A-8OHM

Special Features:

- 3 inch full range/wide band driver
- cosmetic stamped frame
- Ferrite motor
- Paper cone with rubber edge
- designed for high quality multimedia



System Specification

Diaphragm	Paper
Surround	rubber
Nominal Impedance	8 ohm
DCR Impedance	6.85 ohm
Sensitivity 1W/1M	88 dB
Frequency Response	120-20K Hz
Resonant Frequency	120 Hz
Voice Coil Diameter	20.4 mm
Rated Power Input	15 W
Maximum Power Input	20W

Net.Weight	0.4 kg
Moving Mass	1.30 g
Suspension Compl	1356 um/N
Efec Piston Area	0.00283 m ²
Levc@ 1KHz	1.3 mH
X-max	+/-2.6mm
Vas	1.54 L
Qts	0.57
Qms	5.5
Qes	0.64

Mechanical 2D Drawing

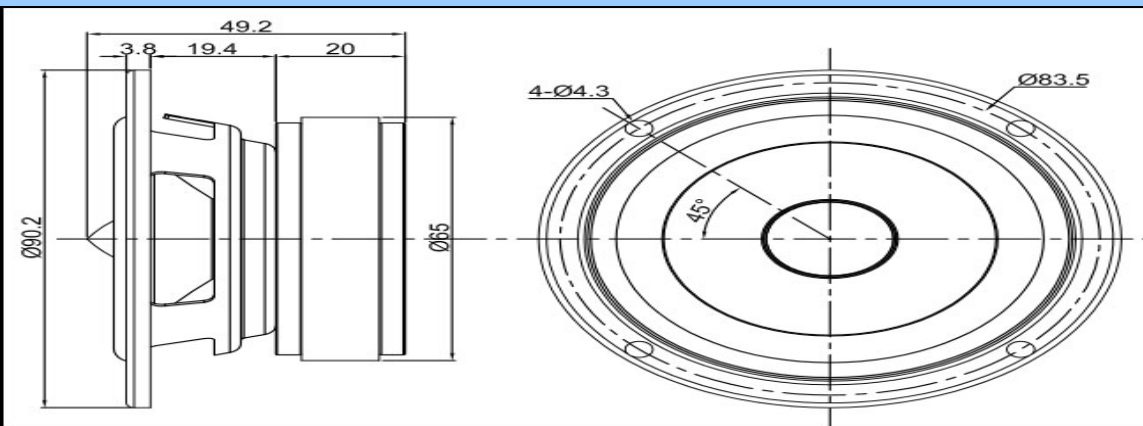

Frequency and Impedance Response

