

## Model:F03B-6OHM

### Special Features:

3 inch full range/wide band driver

Low F0 & high power handling

Neodymium motor

Long magnet gap design

designed for high quality multimedia



### System Specification

Diaphragm	PP
Surround	Polyurethane
Nominal Impedance	6 ohm
DCR Impedance	5.2 ohm
Sensitivity 1W/1M	84 dB
Frequency Response	94-20K Hz
Resonant Frequency	94Hz
Voice Coil Diameter	20.4 mm
Rated Power Input	15 W
Maximum Power Input	20W

Net.Weight	0.3 kg
Moving Mass	2.28 g
Suspension Compl	1290 um/N
Effec Piston Area	0.00283 m2
Levc@ 1KHz	0.9 mH
X-max	+/-3mm
Vas	1.42 L
Qts	0.63
Qms	3.7
Qes	0.75

### Mechanical 2D Drawing

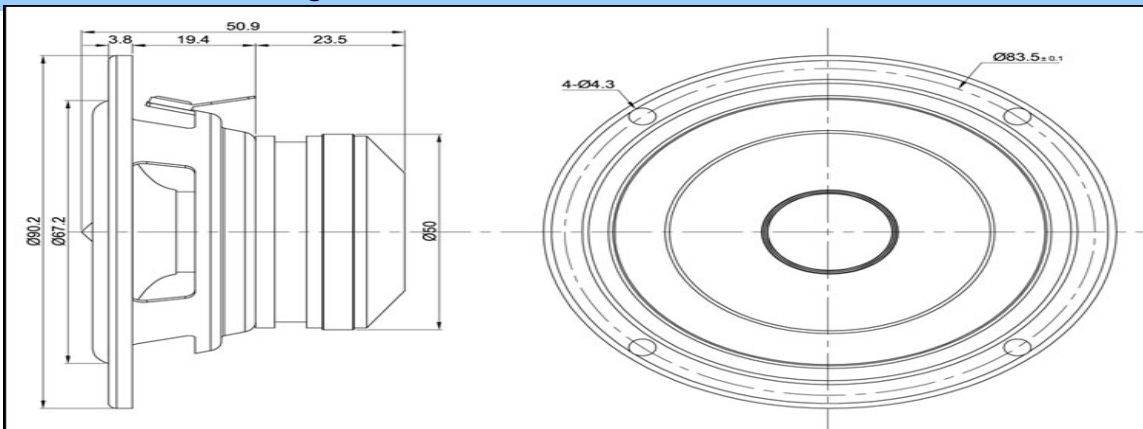

### Frequency and Impedance Response

